

配線用端子〔WTシリーズ〕(1バック1000本入)

- 電線の巻付けによる配線、引掛けによる配線、1点付けによる配線、CRの取付け及びチェック用等に御使用下さい。
- 材質.....黄銅
- 処理.....ニッケル下地金メッキ

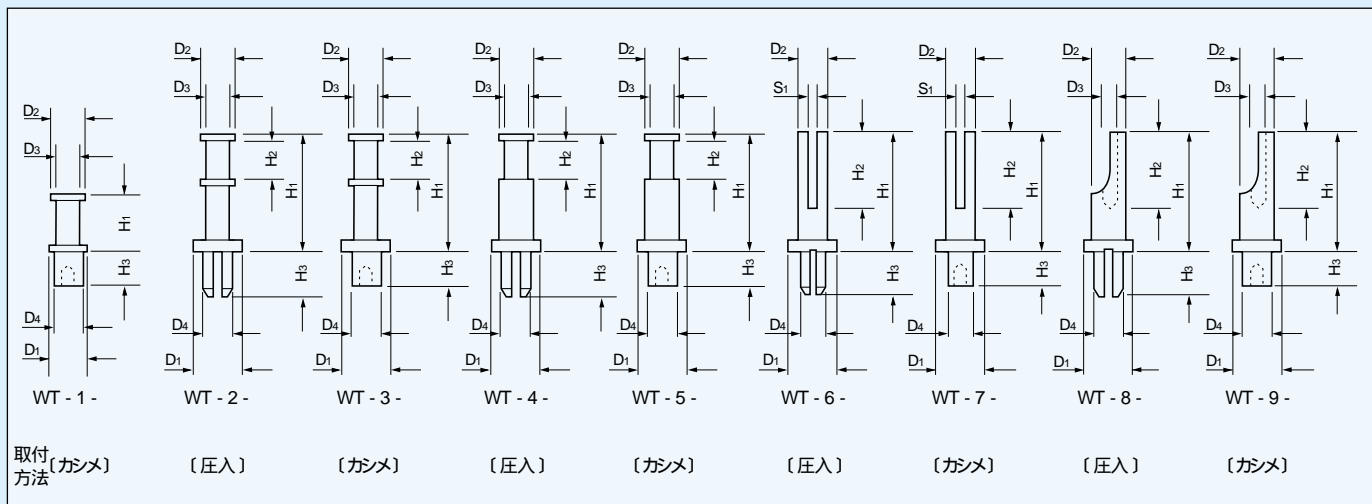
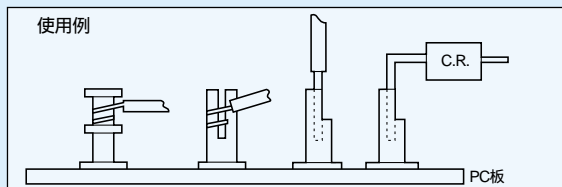

寸法表

品番	D <sub>1</sub>	D <sub>2</sub>	D <sub>3</sub>	D <sub>4</sub>	H <sub>1</sub>	H <sub>2</sub>	H <sub>3</sub>	プリント板取付穴径	圧入工具先端チップ
WT-1-1	2.5	2.0	1.5	1.5	3.95	-	2.35	1.6	
WT-1-2	3.0	2.0	1.5	1.5	5.35	-	2.35	1.8	
WT-1-3	3.5	2.8	1.7	1.9	6.65	-	2.35	2.0	
WT-2-1	3.0	2.2	1.3	1.62	8.0	2.5	3.0	1.6	P - 7
WT-2-2	3.0	2.2	1.3	1.62	8.0	3.5	3.0	1.6	
WT-2-3	4.0	3.0	1.8	2.02	8.5	4.0	3.0	2.0	P - 8
WT-2-4	4.0	3.0	1.8	2.02	8.5	4.0	4.5	2.0(板厚3.2用)	
WT-3-1	3.0	2.2	1.3	1.7	8.0	2.5	2.5	1.8	2.0(板厚3.2用)
WT-3-2	3.0	2.2	1.3	1.7	8.0	3.5	2.5	1.8	
WT-3-3	4.0	3.0	1.8	1.9	8.5	4.0	2.5	2.0	
WT-3-4	4.0	3.0	1.8	1.9	8.5	4.0	4.0	2.0	
WT-4-1	3.0	2.0	1.3	1.62	8.0	2.5	3.0	1.6	P - 7
WT-4-2	3.0	2.0	1.3	1.62	8.0	3.0	3.0	1.6	
WT-4-3	3.0	2.0	1.3	1.62	8.0	3.5	3.0	1.6	
WT-5-1	3.0	2.0	1.3	1.7	8.0	2.5	2.5	1.8	
WT-5-2	3.0	2.0	1.3	1.7	8.0	3.0	2.5	1.8	
WT-5-3	3.0	2.0	1.3	1.7	8.0	3.5	2.5	1.8	
WT-6-1	3.0	2.0	S <sub>1</sub> = 0.8	1.62	8.0	5.0	3.0	1.6	P - 7
WT-6-2	3.0	2.2	S <sub>1</sub> = 1.0	1.62	8.0	5.0	3.0	1.6	
WT-6-3	3.5	2.5	S <sub>1</sub> = 1.2	2.02	8.0	5.0	3.0	2.0	
WT-7-1	3.0	2.0	S <sub>1</sub> = 0.8	1.7	8.0	5.0	2.5	1.8	
WT-7-2	3.0	2.0	S = 1.0	1.7	8.0	5.0	2.5	1.8	
WT-7-3	3.5	2.5	S = 1.2	1.9	8.0	5.0	2.5	2.0	
WT-8-1	2.5	1.6	0.7	1.62	8.0	5.5	3.0	1.6	P - 5
WT-8-2	2.5	1.6	0.8	1.62	8.0	5.5	3.0	1.6	
WT-8-3	3.0	2.0	1.0	1.62	8.0	5.5	3.0	1.6	P - 7
WT-8-4	3.0	2.0	1.2	1.62	8.0	5.5	3.0	1.6	
WT-9-1	2.5	1.6	0.7	1.7	8.0	5.5	2.5	1.8	
WT-9-2	2.5	1.6	0.8	1.7	8.0	5.5	2.5	1.8	
WT-9-3	3.0	2.0	1.0	1.7	8.0	5.5	2.5	1.8	
WT-9-4	3.0	2.0	1.2	1.7	8.0	5.5	2.5	1.8	

圧入工具先端チップPシリーズは本体PCX-1(19ページ参照)がないと出来ません。  
 圧入工具がなくても手で押せば挿入できます。